

GORILLA™

TRUCKBOX



PRODUCT CATALOG

CHEMICALS AND ACCESSORIES

WWW.GORILLATRUCKBOX.COM

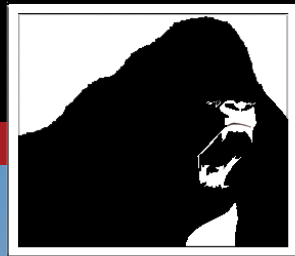

GORILLA™

TRUCKBOX



 GORILLA **G1**

 GORILLA **G2**

 GORILLA **G3**



WWW.GORILLATRUCKBOX.COM



A Place For Everything And Everything In Its Place!

The design team at Gorilla Truck Box has painstakingly looked at how we can build you a truck that is versatile enough to accommodate the tools you need to perform the tasks at hand. On the Gorilla G1 Truck Box, everything has a place, so you can find it quickly and efficiently. The result is a truck that directly translates into better efficiency and productivity on the job site. There will be no more wondering if you have all of your tools from job site. A quick glance in each compartment will tell you what is missing, which will save you time and money.

Passenger Side Compartments

- 1** Compartment size -W 31.125" x H 68.25" x D 13.125"
This compartment has been designed to hold the latest carpet, tile, and upholstery cleaning tools on the market. It's easily customizable for the tools you already own, or you can customize with compartment shelves and removable cases to fit the needs of HVAC/plumbing, electrical, construction, utilities, and telecommunications companies.
- 2** Compartment size -W 46.75" x H 26.50" x D 13"
This compartment has an adjustable shelf that can be customized to fit your needs for a number of miscellaneous items of your choice.
- 3** Compartment size -W 46.75" x H 17" x D 13"
Designed to store gallon chemicals, (21 gallon capacity), to prepare you for any cleaning task. You can also customize by adding shelving with compartments for all of your parts.
- 4** Equipment area -W 91 x D 68.75" x H 64.50" (50 1/2" is door clearance height)
This compartment was designed to permanently mount equipment like truck mounted carpet extractors, slide-in units, plumber jettors, and skid mount pressure washers. The compartment can be used to store HVAC units, hot water tanks, and more! With the 90" wide roll up door, your technician has wide access to their equipment.

Driver Side Compartments

- 5** Equipment Compartment: Compartment size -W 168" x H 23" x D 22"
Designed to fit the latest air movers such as Phoenix Air Max, or DriEaz Velo. This compartment will hold 20 low profile, or 12 old style, air movers. You can store items over 15' long like: oriental rugs, electrical conduit, or plumber's pvc pipe. You can also customize this compartment with bins that incorporate 68 compartments for parts.
- 6** Equipment Compartment: Compartment Size - W 91" x H 23.25" x D 18.50"
Designed to fit the latest air movers like Phoenix Air Max, or Drieaz Velo. This compartment will hold 12 low profile, or 4 old style air movers. You can also customize this compartment with bins holding up to 68 compartments for parts.
- 7** Tool and Equipment: Compartment Size -W 169" x H 34" x D 22 1/2"
Accessible from interior only; You can store air movers, compact dehumidifiers (such as the Phoenix Dry Max), electrical boxes, compact air scrubbers, or almost any tool that fits your needs. You can store items over 15' long like: oriental rugs, electrical conduit, or plumber's pvc pipe.
- 8** Miscellaneous Storage: Size -W 23" x H 24 1/4" x D 18.5"
This compartment is designed to hold a number of items including: drills, electrical cords, carpet tools, small air movers, electrical boxes, or any other compact item that may fit your needs.

Rear Compartments

- 5** Small Rear Door: This gives you access to the driver side compartments. This allows long items, over 15 feet long, to be slid in from the back of the truck, or gives access to tools that are stored in compartments.
- 7**
- 9** Large Rear Door: This gives you access to the storage at the back of the truck.
- 10** Pull-Out Ramp: This makes it easier to load and unload equipment. The extra-large cargo area gives you the versatility you need to perform any task at hand.

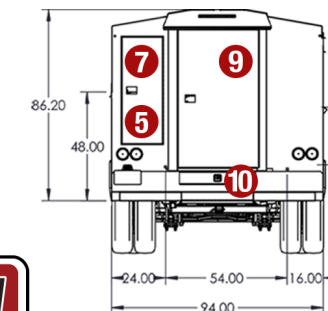
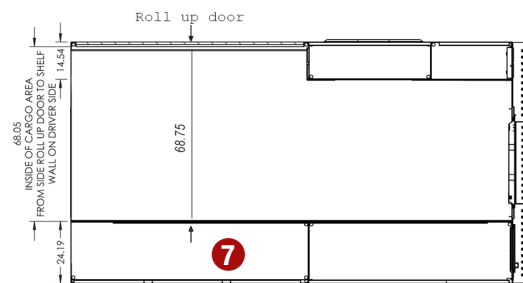

All New Design

Looking for the most versatile enclosed utility body in the industry? Look no further! The Gorilla Truck Box is essential equipment among the professional carpet cleaner, restoration contractor, HVAC/plumbing, electrical, construction, and lawn care service companies.

- The Gorilla G1 Truck Box was specifically built for the contractor that needs to carry a heavy payload. You will have all the power you need to accomplish any task with a payload over 6000 lb (on 5500) and the optional diesel engine, and 4 wheel drive. The Gorilla G1 Truck Box is installed on the truck chassis of your choice: Chevy, Ford, or a Dodge 120" CA with a gas or diesel engine. The crew cab option on Chevy 5500 Silverado allows the contractor to send up to six men in one vehicle to the job site. The 90" wide roll up door makes it easier to mount the largest of truck mounted extractors, pressure washers, plumber jettors, or lawn care spray rigs. The Gorilla G1 Truck Box side accessible compartments enable the contractor to sufficiently organize their tools and equipment without having to crawl in the back of the truck; it directly translates into better efficiency and productivity on the job site.

Highlights

The Gorilla G1 utility body's feature side accessible storage compartments and an oversized cargo area with the option of locking all doors with the push of a button to maximize security. A big part of your livelihood is your tools and equipment; you need a utility truck box that is set up for the way you work. Putting together the ideal work truck will make you more productive, efficient, and contribute more to your bottom line.

- The passenger side of the truck has a large 90" wide roll up door that gives you the versatility to permanently mount your equipment, or store large equipment for installation on location.

- The rear of the Gorilla G1 truck features one large (26.5" wide) door to access the large cargo areas and a smaller door that gives you full access to the more than 15' long compartment on the drivers side of truck. This allows storage of long area rugs, pipes, or equipment of your choice. The ramp gives you easy access to load and unload equipment.

Versatile

The Gorilla G1 Truck Box is designed to fit the needs of most carpet cleaners.

- Custom shelving with removable compartment cases can be designed to fit your needs. Gorilla Truck Box shelving packages for HVAC, plumbing, electrical, and construction contractors turns your truck into a mobile warehouse for all of your resale parts. Think of the time and money that's wasted chasing parts; never again with Gorilla Truck Box.

- So, if you're looking for organization, efficiency, and productivity that will add to your bottom line, then the Gorilla G1 is vital to your success! All the other competitors are just trucks with shelves.

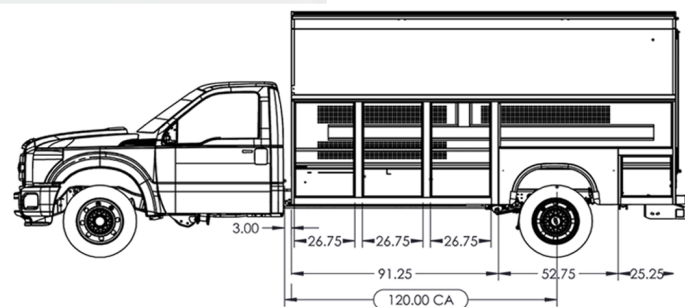
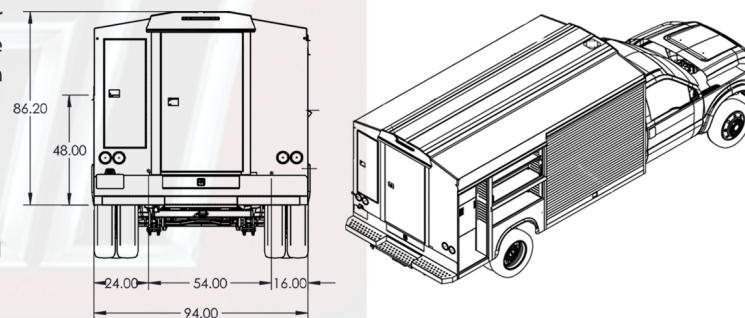

The image above is a rendering and not an actual representation of the Gorilla G1™ vehicle. Slight variations are possible between this rendering and the finished vehicle. Gorilla G1™ is a trademark of Gorilla Truck Box™. Copyright © 2020 Gorilla Truck Box™.



The image above is a rendering and not an actual representation of the Gorilla G1™ vehicle. Slight variations are possible between this rendering and the finished vehicle. Gorilla G1™ is a trademark of Gorilla Truck Box™. Copyright © 2020 Gorilla Truck Box™.



A Whole New Generation of Organized.



More Payload, More Versatility, More Affordable.

A place for everything and everything in its place.

► All New Design

Looking for the most versatile enclosed utility body in the industry? Look no further. The Gorilla Truck Box is essential equipment among the professional carpet cleaner, restoration contractor, HVAC/plumbing, electrical, construction, utilities and telecommunications companies all over the US.

- Built on a Chevy cutaway body with two sizes of trucks available. Chevy 3500 12,300 GVWR with a 4,112 lb. payload or Chevy 4500 14,200 GVWR with a 6,123 lb payload.
- With the Gorilla Truck Box G2 side accessible compartments enables you to sufficiently organize your tools and equipment without having to crawl in the back of the truck, which directly translates into better efficiency and productivity on the job site.

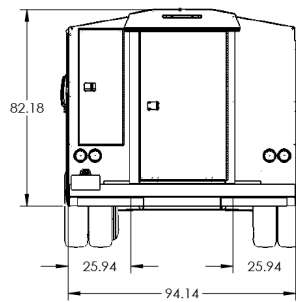
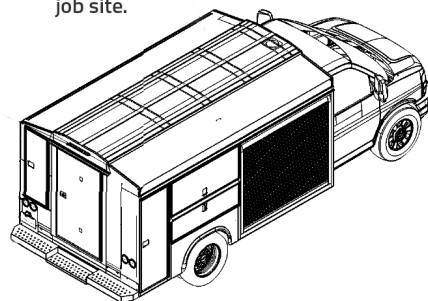

► Highlights

Gorilla G2 utility bodies feature side accessible storage compartments and an oversized cargo area with the option of locking all door with the push of a button to maximize security. A big part of your livelihood is your tools and equipment. You need a utility truck box that is set up the way you work. Putting together the ideal work truck will make you more productive and efficient and contribute more to your bottom line.

- The passenger side of the truck has a large 69" wide roll up door that gives you the versatility to permanently mount your equipment or store large equipment for installation on location.
- The rear of Gorilla G2 truck features two doors, one large 34" wide door that access the large cargo area and a smaller rear access door that enables the technician to store longer items over 12 feet in length or store equipment of your choice.

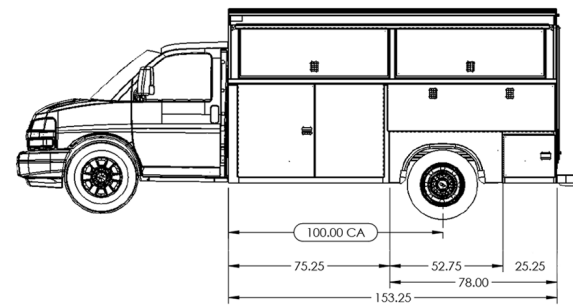
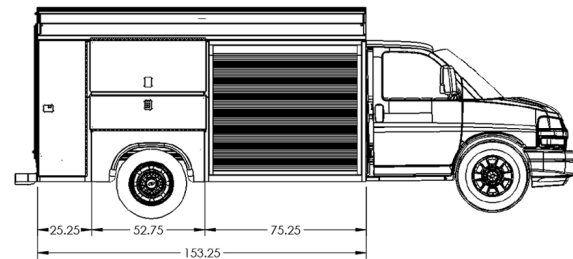

► Versatile, & Affordable

The Gorilla Truck Box G2 is more versatile. Designed to fit the needs of most contractors.

- Custom shelving with removable compartment cases can be designed to fit your needs. Gorilla Truck Box shelving packages for HVAC, plumbing, electrical, and construction contractors turns your truck into a mobile warehouse for all your resale parts. Think of the time and money wasted chasing parts, never again with Gorilla Truck Box with up to 170 individual bin compartments that can be labeled for quick access to your parts inventory, saving you time and money.
- So, if you're looking for organization, efficiency and productivity that will add to your bottom line, then the Gorilla G2 is vital to your success. All the other competitors are just trucks with shelves.



► A Place For Everything And Everything In Its Place!

The design team at Gorilla Truck Box has painstakingly looked at how we can build you a truck that is versatile enough to accommodate the tools you need to perform the tasks at hand. The trade tools, old or new, have been looked at to fit in our Gorilla truck, where everything has a place and is in a place, so you can find it quickly and efficiently. The result is a truck that directly translates into better efficiency and productivity on the job site. No more wondering if have all of your tools from job site, because at a quick glance in each compartment on the Gorilla G2 you will see what is missing, saving you money and time.

Passenger Side Compartments

- 01** **Compartment size -W 25.25"x H 61.57"x D 26.09"**
This compartment has been designed to hold the latest carpet, tile and upholstery cleaning tools on the market. It's easily customizable to the tools you already own, or customize with compartment shelves and removable cases to fit the needs of the HVAC/plumbing, electrical, construction, utilities and telecommunications companies.
- 02** **Compartment size -W 52.75" x H 21.58" x D 24"**
This compartment has an adjustable shelf that can be customized to fit your needs for a number of miscellaneous items of your choice.
- 03** **Compartment size -W 52.75" x H 19.5" x H 52.47" x D 24"**
Designed to store gallon chemicals to prepare you for any cleaning task. (21 gallon capacity) or can customize by adding shelves with compartments for all your parts.
- 04** **Equipment area -W 68.44 x D 66.17" x H70" (50 1/2" is door clearance height)**
This compartment was designed to permanently mount equipment like truck mounted carpet extractors, clutch drive or slide-in units, plumbers jettors or skid mount pressure washers. The compartment can be used to store HVAC units, hot water tanks, etc. with the 69" wide roll up door, the technician has wide access to the equipment.

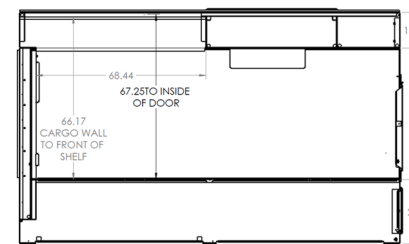

With this top down view, you can see the floor space available to install equipment and see how your portable equipment will fit into the space.

Driver Side Compartments

- 05** **Equipment Compartment: Compartment size -W 75. 25" x H19" x D 24"**
Designed to fit the latest air movers such as Phoenix Air Max or DriEaz Velo. This compartment will hold 12 low profile or 4 old style air movers. Since compartments 5 and 6 our open to each other you can store items over 13' long like oriental rugs for pickup, electrical conduit, plumbers pvc pipe. You can also customize this compartment with bins with up to 68 compartments to hold parts.
- 06** **Equipment Compartment: Compartment Size - W 78" x H 19" x D 24"**
Designed to fit the latest Air movers like Phoenix Air Max or DriEaz Velo. This compartment will hold 12 low profile or 4 old style air movers. You can combine compartments 5 and 6 and slide in an oriental rug up to 13' long. You can also customize this compartment with bins with up to 68 compartments to hold parts.
- 07** **Tool and Equipment: Compartment Size -W 75. 25" x H 19.50" x D 24"**
Compartment 7 has a shelf, level with compartment 8, which will give you the versatility to slide in an oriental rug up to 13' long or use for electrical conduit or pipe. You can also store air movers, 3 compact dehumidifiers (such as the Phoenix Dry Max or DriEaz Revolution), electrical boxes, compact air scrubbers or most any tool that fits your needs. You can also customize this compartment with bins with up to 68 compartments to hold parts.
- 08** **Equipment Compartment: Compartment Size -W 78" x H 19" x D 24"**
Designed to fit the latest air movers, such as Phoenix Air Max or DriEaz Velo. This compartment will hold 8 low profile or 4 old style air movers. This compartment will hold 8 low profile or 4 old style air movers. Since compartments 7 and 8 our open to each other you can store items over 13' long like oriental rugs for pickup, electrical conduit, plumbers pvc pipe.
- 09** **Miscellaneous Storage: Size -W 25.25" x H 19" X D 24"** This compartment is designed to hold a number of items such as drills, electrical cords, carpet tools, small air movers, electrical boxes, or any other that may fit your needs.

Rear Compartments

- 10** **Small rear door:** This gives you access to driver side compartments 5, 6, 7, 8 allowing long items up to 13 feet long to be slid in from the back of the truck, or give access to tools that are stored in compartments.
- 11** **Large Rear door** gives you access to the storage at back of the truck. The extra-large cargo area gives you the versatility you need to perform any task at hand.

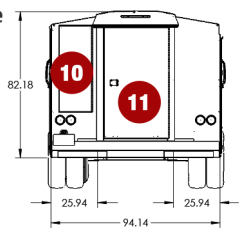

The image above is a rendering and not an actual representation of the Gorilla G2™ vehicle. Slight variations are possible between this rendering and the finished vehicle. Gorilla G2™ is a trademark of Gorilla Truck Box™. Copyright © 2016 Gorilla Truck Box™.



The image above is a rendering and not an actual representation of the Gorilla G2™ vehicle. Slight variations are possible between this rendering and the finished vehicle. Gorilla G2™ is a trademark of Gorilla Truck Box™. Copyright © 2016 Gorilla Truck Box™.

1-888-313-8173
WWW.GORILLATRUCKBOX.COM



Custom Designed for the Professional Carpet Cleaner.

A place for everything and everything in its place.

► All New Design

Looking for the most versatile enclosed utility body in the industry? Look no further. The Gorilla Truck Box is essential equipment among the professional carpet cleaner, restoration contractor, HVAC/plumbing, electrical, construction, utilities and telecommunications companies all over the US.

- Built on a Ford Transit cutaway body . 10,360 GVWR with a 3,140 lb. payload.
- With the Gorilla Truck Box G3 side accessible compartments enables you to sufficiently organize your tools and equipment without having to crawl in the back of the truck, which directly translates into better efficiency and productivity on the job site.

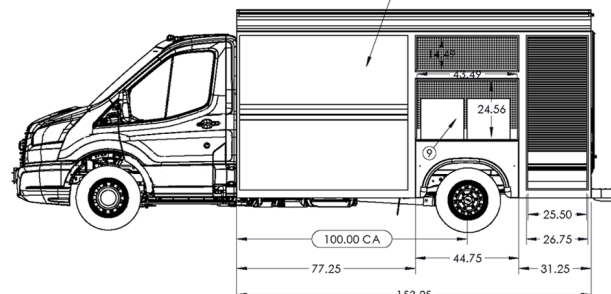
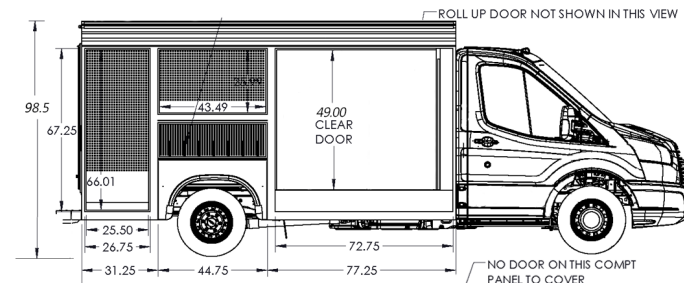
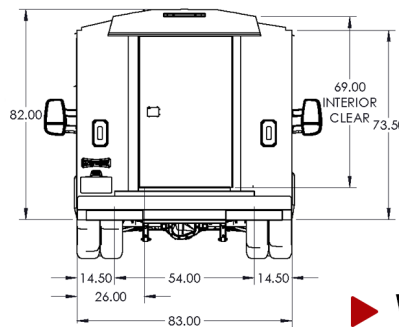
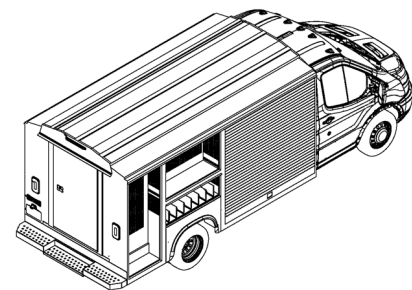

► Versatile, & Affordable

The Gorilla Truck Box G3 is more versatile. Designed to fit the needs of most capet cleaners.

- Custom shelving with removable compartment cases can be designed to fit your needs. Gorilla Truck Box shelving packages for HVAC, plumbing, electrical, and construction contractors turns your truck into a mobile warehouse for all your resale parts. Think of the time and money wasted chasing parts, never again with Gorilla Truck Box.
- So, if you're looking for organization, efficiency and productivity that will add to your bottom line, then the Gorilla G3 is vital to your success. All the other competitors are just trucks with shelves.



► A Place For Everything And Everything In Its Place!

The design team at Gorilla Truck Box has painstakingly looked at how we can build you a truck that is versatile enough to accommodate the tools you need to perform the tasks at hand. The trade tools, old or new, have been looked at to fit in our Gorilla truck, where everything has a place and is in a place, so you can find it quickly and efficiently. The result is a truck that directly translates into better efficiency and productivity on the job site. No more wondering if have all of your tools from job site, because at a quick glance in each compartment on the Gorilla G3 you will see what is missing, saving you money and time.

Passenger Side Compartments

- 01 Compartment size -W 25.25"x H 63"x D 13" door clearance. This compartment has been designed to hold the latest carpet, tile and upholstery cleaning tools on the market. It's easily customizable to the tools you already own, or customize with compartment shelves and removeable cases to fit the needs of the HVAC/plumbing, electrical, construction, utilities and telecommunications companies.
- 02 Compartment size -W 38.5" x H 23.5" x D 13" This compartment has an adjustable shelf that can be customized to fit your needs for a number of miscellaneous items of your choice.
- 03 Compartment size -W 43" x H 13" x D 13" Designed to store gallon chemicals to prepare you for any cleaning task. (12 gallon capacity) or can customize by adding shelves with compartments for all your parts.
- 04 Equipment area -W 68.5" x D 81" x H 65" (W 49 X H 66 is door clearance height) This compartment was designed to permanently mount equipment like truck mounted carpet extractors, clutch drive or slide-in units, plumbers jettors or skid mount pressure washers. The compartment can be used to store HVAC units, hot water tanks, etc. with the 66" wide roll up door, the technician has wide access to the equipment.

Driver Side Compartments

- 05 Equipment Compartment: Compartment Size - W 38" x H 19" x D 24" Designed to fit the latest Air movers like Phoenix Air Max or Drieaz Velo. This compartment will hold 4 low profile or 2 centrifugal style air movers or the equipment of your choice.
- 06 Equipment Compartment: Compartment Size -W 43" x H 19" x D 24" Designed to fit the latest Air movers like Phoenix Air Max or Drieaz Velo. This compartment will hold 4 low profile or 2 centrifugal style air movers or the equipment of your choice.

- 07 Equipment Compartment: Compartment Size - W 25.25 X H 54.25 X D 25 Store your rotary machines, extractors and more with access from the outside as well as being able to access from inside the cargo areas as well. Storage shelf below.



With this top down view, you can see the floor space available to install equipment and see how your portable equipment will fit into the space.

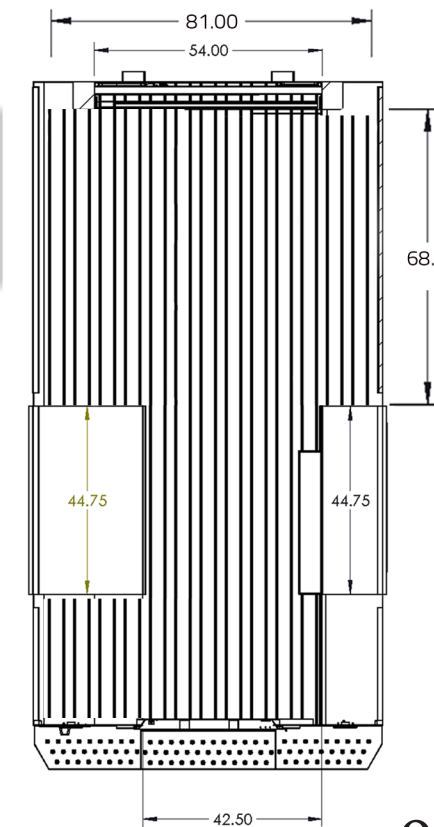



Gorilla Truckbox Heavy-Duty Zippers



2 X Heavy Duty Adhesive Zippers 7 ft long
 2 -Pack includes two heavy-duty zippers
 Create a dust barrier quickly wherever needed.
 Setup Containment for Mold,
 Dust and anywhere containment is required.
 Peel And Stick zipper access



"C"
Style
Zipper



"L"
Style
Zipper



Double
Zipper
Pack
Zipper

Foam Rail System 48 inches long





Gorilla Truckbox Chemicals is a comprehensive line of over 50 awesome products for the carpet cleaning and restoration industry. Quit monkeyin' around with those other brands, get Gorilla Chemicals today!



This icon means we'll ship case quantities of a product anywhere in the lower 48 states for free.



HERE'S WHAT YOU GET...

The Gorilla Professional Spotting Kit includes: up to 7 unique chemicals for virtually any spot you come across. From urine and pet stains to wine and red liquid spills and everything in between. You'll also receive a spotting brush, gum getter, and a towel.



Gorilla FLEX Advanced High Alkaline Pre-Spray

Gorilla FLEX is an advanced high alkaline traffic lane cleaner/pre-spray formulated to be effective on heavily soiled and trashed synthetic carpeting. Gorilla FLEX provides you with superior cleaning effectiveness when compared to other restorative carpet cleaning pre-sprays. It is extremely effective and aggressive on grease, soil, food, oxidized oils, fine particulate clay based soiling, and even filtration soiling. Even with its incredibly aggressive formula, Gorilla FLEX is safer to use than other heavy duty cleaners.

Dilution

For Heavy Soiling 1:12
For Medium Soiling 1:20



Olefin Eraser Traffic Lane Cleaner

Olefin Eraser Traffic Lane Cleaner and Carpet Preconditioning Agent is an advanced high alkaline traffic lane cleaner/pre-spray formulated to be effective on heavily soiled and trashed synthetic carpeting. Olefin Eraser provides you with superior cleaning effectiveness when compared to other restorative carpet cleaning presprays. It is extremely effective and aggressive on grease, soil, food, oxidized oils, fine particulate clay based soiling, and even filtration soiling.

Dilution

For Heavy Soiling 1:8
For Medium Soiling 1:16



Gorilla SLAM Advanced High Alkaline Pre-Spray

Gorilla Slam is an economical highly concentrated pre-spray for carpets. Especially designed for removal of heavy soils, grease, and spills on the filthiest of carpets. Gorilla Slam is very effective on Olefin carpets and has a nice orange scent. Gorilla Slam is not designed to be used on 5th generation fibers. For 5th Generation Fibers try our Gorilla EraserPac for all your stain resistant carpets.

Dilution

For Heavy Soiling 1:16
For Medium Soiling 1:32



EraserPac Concentrated Pre-Spray

This ultra concentrated carpet prespray is ideal for cleaning heavily soiled traffic lanes and overall carpet preconditioning. EraserPac delivers cost-effective, high quality cleaning at concentration rates unrivaled in the carpet cleaning industry. It starts to work as soon as it is applied and literally melts away even the most stubborn soiling as it dissolves, emulsifies, suspends and deflocculates soil and grease. It powers through the filthiest grime. Safe to be used on 5th Generation Fibers

Dilution

For Normal Soiling 1:64
For Heavy Soiling 1:32



Erase HD Heavy Duty Pre-Spray

Erase HD is especially formulated to clean the most extremely soiled carpets. Use on the toughest cleaning jobs like apartments, restaurants and commercial cleaning. This high performance cleaner quickly suspends and emulsifies even the most stubborn soils instantly. Erase HD is to be used as a pretreatment on heavily soiled carpets and should be extracted after use. Erase HD is not designed to be used on 5th generation fibers. For 5th Generation Fibers try our EraserPac for all your stain resistant carpets.

Dilution

For Heavy Soiling 1:8
For Medium Soiling 1:16



Enzyme Grease Eater With OrangeSolv

Enzyme Grease Eater is especially formulated to dissolve grease and oils and protein soils making them ready for extraction. It works great in restaurants and on problem soils found in homes and apartments. Enzyme Grease Eater is economical to use. It can be diluted for use with any type of sprayer for pennies per diluted gallon.

DIRECTIONS FOR USE

For Heavy Soil, mix 3 oz. Enzyme Grease Eater in one gallon warm water.

For Moderate soil, mix 1 to 2 oz. Enzyme Grease Eater in one gallon warm water.

For injection sprayers like Hydro-force, mix 12 oz. of Enzyme Grease Eater in 5 quarts of warm water.



Erase HD Powder With Orange Solv

Erase HD Powder with OrangeSolv is a heavy duty carpet pre-spray designed for use in injection sprayers, pump, and electric sprayers. Best results are obtained from using hot water.

- Ultra concentrated enhanced, high alkaline prespray for restorative carpet treatment.
- Works on contact and dissolves grease and oils in minutes and is ideal for any restorative carpet cleaning application.
- Costs you much less per gallon when compared to other restorative high alkaline presprays.
- Less foamy than typical high pH presprays.
- Leaves carpet smelling citrus fresh.

Dilution

Pump or Electric Sprayers - Dilute 1 scoop (2 ounces) of Erase HD Powder with OrangeSolv per gallon of hot water for most soils. Use up to 2 scoops (4 ounces) of Erase HD Powder with OrangeSolv per gallon of hot water for heavily soiled carpets.

Injection Sprayer - Dilute 8 scoops (16 ounces) of Erase HD Powder with OrangeSolv per Injection Sprayer container of warm water. Dilute at 1 to 8 setting.



Super Foamy Carpet & Upholstery Shampoo

Super Foamy is specifically designed for shampooing machines, foam machines and shampoo scrubbers and is perfect for cleaning upholstery using the foam method. Super Foamy is highly concentrated blend of detergents and surfactants that is effective on removal of surface oils and soil. Super Foamy cleans and revitalizes nylon, acrylic, cotton, wool and many other synthetic fibers. Pretest before use is recommended.

Dilution

For Normal Soiling 1:64
For Heavy Soiling 1:32



CARPET PRESPRAYS



Traffic Control

Traffic Control is the ultimate prespray for all Olefin and Polyester carpets and works just as well on commercial nylon. Innovative blends of micro-emulsion surfactants and emulsifiers will give you full control of those high traffic areas.

Dilution

Pump or Electric Sprayer: 1:32

Case: Includes 4 gallons

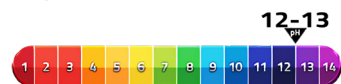

Super Slurry Extraction Emulsifier

Super Slurry cleans heavily soiled residential and commercial carpeting and is safe for stain resistant carpet. Super Slurry will not leave a sticky residue common with extraction emulsifiers which promotes carpet resoiling. This product is highly concentrated for economical use.

Dilution

Portable: 1 oz. / 5 Gal.

Truck Mount : 1 pt. / 5

Case: Includes 4 gallons

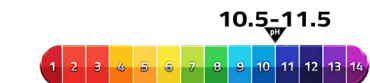

Peroxified Encapsulation Cleaner

Peroxified is a 5 in 1 multi-purpose hydrogen peroxide activated and encapsulating polymer fortified carpet cleaning agent. It combines a synergistic hydrogen peroxide detergent blend with a special encapsulating polymer. The special peroxide blend oxygenates and activates the cleaning power of the polymers and surfactants, and also helps effectively remove many spills and spots (coffee, wine, blood, urine caused discoloration, and more) during the cleaning process.

Dilution

For Heavy Soiling 1:8

For Normal Soiling 1:12

Case: Includes 4 gallons



All Carpet Rinse

All Carpet Rinse is an acid rinse to neutralize pH in carpet and upholstery. It is extremely effective in removing soap residue from carpets. It has a clean, fresh fragrance that will leave all carpet smelling great. It also can be used as urine treatment to neutralize urine salts. All Carpet Rinse can also reverse yellowing in olefin carpet.

Dilution

Truckmount use: Mix 1 quart into 5 gallons of water to make truckmount concentrate. Set flow meter at 2 gallons per hour.

Portable use: Mix 1 ounce to a gallon of water.

Urine treatment: Mix 6-8 ounces/gallon. Saturate carpet urine spot area allow 15 minutes than extract. For total odor removal follow with urine attack pet odor eliminator.

Yellowing on olefin: Mix 6-8 ounces to one gallon and spray directly on carpet. (no need to extract yellowing should disappear.)

Case: Includes 4 gallons



Encapsulate Bonnet / Brush Encapsulation Cleaner

Based on the latest technology in polymer surfactant cleaning, Encapsulate absorbs and cleans the worst soil. The soil is absorbed into a bonnet or suspended for later vacuuming when used with brush method. Remaining residue retards resoiling. This makes vacuuming more effective and is the foundation for an excellent maintenance system for commercial carpet.

Dilution

For Heavy Soiling 1:8

For Normal Soiling 1:12

Case: Includes 4 gallons



Eraser Rinse

Eraser Rinse is a unique dual purpose product that emulsifies and neutralizes PH in one step. Eraser Rinse also controls wicking and re-soiling with encapsulation technology. Full strength cleaning power for all types of soil. It improves bonding and performance of protectors by neutralizing residue. It is highly concentrated for truckmounts and portable use. Works well with very hot water to cold water. It is especially designed to improve working performance and neutralize all pre-sprays. For the perfect cleaning combination pre-spray with Gorilla EraserPac and rinse with Gorilla Eraser Rinse.

Dilution

Truckmount use: Mix 1 quart to 5 gallons of water and meter through truckmount at desired GPH (1-3 is recommended)

Portable use: For normal soiling use 2oz of Eraser Rinse to five gallons of water.

For Extreme soiling use 2oz of Eraser Rinse to one gallon of water.

Case: Includes 4 gallons



EMULSIFIERS DETERGENTS/RINSES



Blue Thunder

Blue Thunder is a new generation carpet extraction detergent powder with environmentally safe solvents, that quickly cut through grease and the toughest of soil and leaves the carpet clean. Blue Thunder is powerful enough for commercial buildings and restaurant carpets, yet it is also safe for residential carpet. This product can be used as a primary cleaning agent or as a rinsing agent in the extraction process for carpets.

Dilution

Truckmount use: To make a truckmount concentrated slurry, mix 1 1/2 Lbs (3 cups or about 12 scoops) of Blue Thunder into 5 gallons of hot water mix until completely dissolved. Set truckmount chemical feed system from 2 to 3 GPH.

Portable use: Mix 1/2 to 3/4 of an ounce of Blue Thunder per gallon of hot water. Mix until completely dissolved.

Case: Includes 4 8 lb. tubs

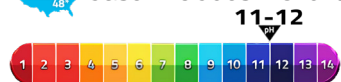

Peroxi Orange Booster

Peroxi Orange Booster adds the power of oxygen and the power of delimonene in one great product. Add to your cleaning solutions to boost cleaning effectiveness and brighten the finished look. Alkaline builders and color safe oxygen bleach with delimonene supercharges carpet and upholstery cleaning solutions to remove heavy soiling and brighten dingy traffic lanes!

Peroxi Orange Booster has a variety of uses. Add Peroxi Orange Booster to your favorite carpet or upholstery pre-spray. Add to your laundry detergent to boost its cleaning effectiveness. Use on fringes of oriental rugs to change that dingy dirty look to a like new bright white look.

Case: Includes 4 8 lb. tubs

Dilution

Pre-Spray Booster - Use 1/4 to 1/2 ounce of Peroxi Orange Booster per gallon of ready-to-use cleaning solution.

Upholstery Cleaning Booster - Use 1/4 to 1/2 ounce Peroxi Orange Booster per gallon of cleaning solution with either the extraction or shampooing cleaning method.

Fringe Cleaner - Add 1/2 ounce Peroxi Orange Booster per quart of water. Spray on fringe only and allow 15 minutes dwell time before extraction.

Laundry Booster - Use 1/4 to 1/2 ounce per gallon of water. Wash machine size and capacity vary by brand, use accordingly.



EMULSIFIERS DETERGENTS/RINSES

CARPET CLEANING BOOSTERS

CARPET CLEANING BOOSTERS



Orange Solv Spotter & Booster
Orange Solv is a powerful concentrated citrus based solvent / booster. Effective as a spotter for tar, grease, cosmetics, lipstick, ink, gum, etc. Use as a booster to your favorite pre-spray for carpet or upholstery. It can be added to your cleaning solution when doing fire restoration. In addition, your customers will love the natural smell of oranges.



Dilution
2-4oz. / Gal. as a booster
As a Spotter: Ready To Use. Do Not Dilute

Case: Includes 4 gallons
Quart Case: Includes 12 quarts



CARPET PROTECTOR



Resistance Carpet Protector
Resistance Carpet Protector is the latest technology in short chain fluorochemicals and the latest generation of dye blocking with acid dye resistors. Resistance Carpet Protector provides superior performance in stain resistance.

Dilution
1:6

Case: Includes 4 gallons



UPHOLSTERY CLEANER



Soft Touch Upholstery Shampoo
Soft Touch Pre-spray is a special blend of detergents, solvents, and builders. It is formulated to emulsify the toughest soils and oils found in upholstery while leaving your upholstery with a soft touch like when it was new. It is also very effective on wool rugs and carpets where lower ph is required.

Dilution
For Heavy Soiling 1:4
For Medium Soiling 1:10

Case: Includes 4 gallons

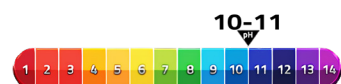

PET ODORS



Urine Attack Pet Spotter For Urine
Urine Attack eliminates the need for harsh chemicals. It is 100% biodegradable, non-corrosive, non-toxic, non-pathogenic, and it has billions of safe microbes. Urine Attack is especially formulated to destroy uric acid odors caused by pet and human urine. Urine Attack works best when allowed to penetrate porous surfaces where the sources of many mal-odors thrive.



Dilution
1:1

Case: Includes 4 gallons
Quart Case: 12 qt.



PET ODORS



UTA Neutralizer
UTA Neutralizer is especially formulated to be effective for the pre-treatment of urine contamination on carpet, upholstery, mattresses and most soft surfaces. It neutralizes and dissolves alkaline salt residues that build up from pet accidents and other urine contamination. UTA enhances the performance of and speeds up the deodorizing process when used before applying an enzyme treatment.



Dilution
Gallon - 1:6
Qt. Ready To Use. Do Not Dilute

Case: Includes 4 gallons
Quart Case: 12 qt.

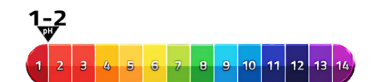

Odor Eraser Odor-Cide For Serious Pet Odors
Odor Eraser is a severe odor counteractant that safely and immediately neutralizes odors associated with animals, humans, food, and smoke. It works instantly with no dwell time. Use on carpet, upholstery, mattress, pet bedding, and rest rooms to permanently eliminate odor caused by pet urine, human waste, feces, decayed matter, vomit, garbage, and smoke. It also works great to eliminate odors in bird and reptile cages. Available in a 1 gallon concentrate, a 1 quart ready to use product, and a one pint measuring bottle.



Dilution
For General Deodorizing 1:256
For Serious Odors 1:16

Case: Includes 4 gallons
Pint Case: 12 pints



Urine Stain Eraser
Urine Stain Eraser is specially formulated to remove that tough yellow stain on carpet and upholstery that is associated with pet stains. This product also eliminates any residual odors, it does not mask odors it eliminates them. Follow directions closely.

DO NOT USE ON NATURAL FIBERS.



Dilution
Ready To Use. Do Not Dilute
Case: Includes 4 gallons
Quart Case: 12 qt.



Urine Stain Eraser

Directions For Use:

1. Wear protective gloves when using this product.

2. Always pretest in an inconspicuous area and wait the appropriate time (5-10 minutes) to test for color fastness before proceeding with treatment.



3. Thoroughly vacuum/clean area to be treated.

4. Apply Urine Stain Eraser full strength directly to urine stain.

5. Blot area with clean white absorbent towel.

6. May take a few minutes to a few hours for stain to disappear. (Odor removal should be immediate.)





GORILLA TRUCKBOX™



FOR ODOR PROBLEMS
LARGE
& **SMALL**

ODOR ERASER

A severe odor counteractant that safely and immediately neutralizes odors associated with animals, humans, food, and smoke. It works instantly with no dwell time. Use on carpet, upholstery, mattress, pet bedding, and rest rooms to permanently eliminate odor caused by pet urine, human waste, feces, decayed matter, vomit, garbage, and smoke. It also works great to eliminate odors in bird and reptile cages.



DEODORIZERS

Gorilla Chemicals Deodorizers

Our deodorizers absorb odor molecules on contact and remove unpleasant odors instantly. It does not mask odors it eliminates them. These products eliminate odors caused by mold, mildew, bacteria, sewage, urine, vomit, and other organic odors. These products can also be used on air scrubbers and air handling equipment to remove odors.

Dilution

1:32 to 1:50

Case: Includes 4 gallons

Case: Includes 4 gallons



Decon 1 Cleaner

Decon 1 is a biological decontamination treatment with 500 billion spores that will digest odors and soils caused by water and sewer damages. Treats category 1, 2, 3 losses. Decon 1 is also great for soils from trauma body fluids and blood. Heavily contaminated carpet tile and concrete caused by pet urine and feces.

Billing Code:
WTRGRMBIO

Dilution

1:4 - 1:10 for pet urine
and water damages

Case: Includes 4 gallons



RESTORATION



IS YOUR HOME A BURN VICTIM?
WE PRESCRIBE **RESTORATION RX**



SOOT REMOVER & RESTORATIVE CLEANER

Restoration RX was especially designed for soot clean up after fire damage has occurred. This one product does it all. Restoration RX will effectively remove soot from almost all home content items and semi-gloss painted walls and trim common in most fire damage restoration jobs. It will provide professional results on soot damaged carpet and upholstery and against most food and beverage spills, blood, iodine, grease, tar, pet stains, smoke, also makes a great laundry booster for soot damaged clothes.

DILUTION

Content Cleaning - RTU
Wall Cleaning - 1:1 - 1:20 (Dependant on severity of smoke damage.)
Upholstery Cleaning - RTU Liberal mist
Carpet Cleaning - RTU Liberal mist



DEGREASERS / SPECIALTY PRODUCTS



Flash Degreaser

Flash is a concentrated, heavy-duty butyl cleaner/degreaser. For use in industrial equipment cleaning, commercial kitchens and other heavy-duty applications.

Dilution

Floor Cleaning - 1:30
Concrete - 1:10
Stoves, Hoods, Ovens - RTU
Engines - 1:5
Pressure Washing - 1:100
Painted Surfaces - 1:40

Case: Includes 4 gallons

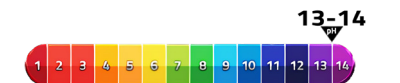

Restoration RX Cleaner

SOOT REMOVER & RESTORATIVE CLEANER

Restoration RX was especially designed for soot clean up after fire damage has occurred. This one product does it all. Restoration RX will effectively remove soot from almost all home content items and semi-gloss painted walls and trim common in most fire damage restoration jobs. It will provide professional results on soot damaged carpet and upholstery and against most food and beverage spills, blood, iodine, grease, tar, pet stains, smoke, also makes a great laundry booster for soot damaged clothes.

Dilution

1:1 -1:20
Dependant on severity of smoke damage

Case: Includes 4 gallons

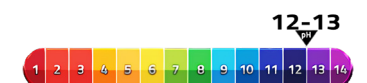

Foam Eraser Liquid

Foam Eraser Liquid is a blend of anti-foaming agents and water conditioners. It is intended for commercial use in carpet extraction and cleaning equipment. It can also be used in automatic scrubbers and other vacuum operated systems. This concentrated defoamer is designed to eliminate foaming due to residue left by carpet cleaning chemicals and other foaming cleaners. It quickly knocks down foam to give more efficient pick-up of extractor detergent solutions, and prevents foaming in the recovery tanks. Foam Eraser Liquid can be used in other powered equipment that requires an anti-foaming agent. Always apply a small amount to test for effectiveness.

Uses

If foaming occurs on the carpet or in the recovery tank, pour 2 ounces of defoamer into the vacuum hose. This will eliminate foam in hoses and the recovery tanks. Foam Eraser Liquid can also be added directly to the recovery tank of the extraction equipment or automatic scrubber.

Case: Includes 4 gallons

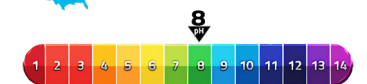

Foam Eraser Powder

Foam Eraser Powder is a blend of anti-foaming agents and water conditioners. It is intended for commercial use in carpet extraction and cleaning equipment to eliminate foaming from detergent residues left in carpet. It can also be used in automatic scrubbers and other vacuum operated systems. This powerful defoamer is designed to eliminate foaming due to residue left by carpet cleaning chemicals and other foaming cleaners. It quickly knocks down foam to give more efficient pick-up of extractor detergent solutions, and prevents foaming in the recovery tanks. It can be used in other powered equipment that requires an anti foaming agent. Always apply a small amount to test for effectiveness.

Uses

Before extraction, lightly and evenly apply powdered defoamer directly to carpet. Generally a few table-spoons per 100 square feet of carpet are needed to completely prevent foaming. If carpet contains an extra heavy detergent residue from previous cleanings, increase the quantity of powder used.

Case: Includes 4 8 lb. tubs





Decon 1 Cleaner

Decon 1 is a biological decontamination treatment with 500 billion spores that will digest odors and soils caused by water and sewer damages. Treats category 1, 2, 3 losses. Decon 1 is also great for soils from trauma body fluids and blood. Heavily contaminated carpet tile and concrete caused by pet urine and feces

Billing code:
WTRGRMBIO

Dilution
1:4 - 1:10 for pet urine
and water damages

Case: Includes 4 gallons



Truck Mount Descaler Cleaner

Truck Mount Descaler is especially designed to breakdown and dissolve hard water deposits and scale in truck mounted carpet cleaning machines and pressure washers.

Dilution
1:4

Case: Includes 4 gallons

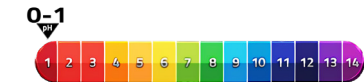

Orange Solv Spotter & Booster

Orange Solv is a powerful concentrated citrus based solvent / booster. Effective as a spotter for tar, grease, cosmetics, lipstick, ink, gum, etc. Use as a booster to your favorite pre-spray for carpet or upholstery. It can be added to your cleaning solution when doing fire restoration. In addition, your customers will love the natural smell of oranges.



Dilution
2-4oz. / Gal. as a booster
As a Spotter: Ready To Use.
Case: Includes 4 gallons
Quart Case: 12 qt.

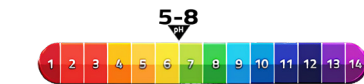

Peroxy Orange Citrus Cleaner

Peroxy Orange Citrus Cleaner is the natural solution for all cleaning tasks. It is made with a blend of organic surfactants, citrus oils, and hydrogen peroxide. Peroxy Orange Citrus Cleaner is intended for all hard surfaces such as floors, walls, restrooms, shower rooms, kitchens, carpeting, upholstered furniture, glass, and all other surfaces not harmed by water.

Dilution
1-8 oz. / Gal. cleaner
Case: Includes 4 gallons



Rust Eraser

Rust Eraser effectively removes rust stains from carpet, upholstery and other textile surfaces.

Dilution

Ready to Use. Do Not Dilute.

Case: Includes 4 gallons
Quart Case: 12 qt.



Red Out Dye Remover

Red Out is a one part dye remover no mixing required. Red Out is especially formulated to remove all types of food dyes. Unlike some red dye removing products, Red Out is effective in removing red stains without using a heat transfer method. Follow all directions closely.

Dilution

Ready To Use. Do Not Dilute

Case: Includes 4 gallons
Quart Case: 12 qt.



Urine Stain Eraser

Urine Stain Eraser is specially formulated to remove that tough yellow stain on carpet and upholstery that is associated with pet stains. This product also eliminates any residual odors, it does not mask odors it eliminates them. Follow directions closely.

DO NOT USE ON NATURAL FIBERS.

Dilution

Ready To Use. Do Not Dilute

Case: Includes 4 gallons
Quart Case: 12 qt.

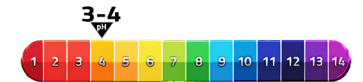

SPOT & STAIN REMOVERS



Stain Eraser

Stain Eraser is a powerful oxidizing stain remover designed to remove the toughest stains. Stain Eraser is a one part ready to use stain remover – no mixing necessary. Ideal for use on wood stains from furniture, mustard, yellowing from urine contamination, shoe polish, coffee, vomit, and other staining materials. For food dye stains like red Kool-Aid use Red Out.

Dilution

Ready To Use. Do Not Dilute

Case: Includes 4 gallons
 Quart Case: 12 qt.

SPOT & STAIN REMOVERS



Dry Volatile Solvent

Dry Volatile Solvent is a dry cleaning solvent designed for cleaning all fibers. Safe on all fabrics or fibers labeled or coded with “s” cleaning designation. Try Dry Volatile Solvent first on unknown stains without fear of color bleeding, distortion or browning. Dry Volatile Solvent is an effective spotter for removing difficult oil-based spots and stains like oil, tar, and greasy soils.

Dilution

Ready To Use. Do Not Dilute

Case: Includes 4 gallons
 Quart Case: 12 qt.



UTA Neutralizer

UTA Neutralizer is especially formulated to be effective for the pre-treatment of urine contamination on carpet, upholstery, mattresses and most soft surfaces. It neutralizes and dissolves alkaline salt residues that build up from pet accidents and other urine contamination. UTA enhances the performance of and speeds up the deodorizing process when used before applying an enzyme treatment.



Dilution

Gallon - 1:6
Qt. Ready To Use. Do Not Dilute

Case: Includes 4 gallons
 Quart Case: 12 qt.

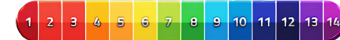

Gum Buster

A gel based spotter designed to remove gum from carpet, upholstery and hard surfaces. Ideal for oil, grease, tar, ink, gum, etc. Always pre-test in a small inconspicuous area for safety and fabric compatibility. Shake well before using.

Dilution

Ready To Use. Do Not Dilute

Case: Includes 4 gallons
 Quart Case: 12 qt.



Browning Treatment

Browning Treatment is specially formulated to effectively deal with two of the most problematic and common carpet issues – browning and coffee stains. This solution is extremely effective on removing or preventing cellulosic and other types of browning. Browning Treatment removes or reduces browning due to over wetting and bleed through of jute backing in carpets.



Dilution

Read To use. Do Not Dilute

Case: Includes 4 gallons
 Quart Case: 12 qt.

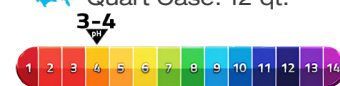

Spot Avenger

Spot Avenger was developed with space age technology by cross linking incompatible chemicals and bonding these with unique wetting and emulsifying agents. Spot Avenger will effectively treat and remove almost all common spills and stains. It will provide professional results against most food and beverage spills, blood, iodine, grease, tar, pet stains, smoke, also makes a great laundry booster.



Dilution

Normal Soiling: 1:4
Qt. Ready To Use. Do Not Dilute

Case: Includes 4 gallons
 Quart Case: 12 qt.



P.O.G.I.

P.O.G.I. is a non-volatile multi-purpose solvent used on carpet and fabric. P.O.G.I. is especially formulated to remove paint, oil, grease, ballpoint pen ink, markers, cosmetics and some adhesives.



Dilution

Ready To Use. Do Not Dilute

Case: Includes 4 gallons
 Quart Case: 12 qt.



Urine Attack [Pet Spotter For Urine](#)

Urine Attack eliminates the need for harsh chemicals it is 100% biodegradable, non-corrosive, non-toxic, non-pathogenic, and it has billions of safe microbes. Urine Attack is especially formulated to destroy uric acid odors caused by pet and human urine. Urine Attack works best when allowed to penetrate porous surfaces where the sources of many malodors thrive.



Dilution

1:1

Case: Includes 4 gallons
 Quart Case: 12 qt.



HARD SURFACE / CLEANING



Snake Venom Alkaline Cleaner

Snake Venom is a high alkaline butyl tile and grout cleaner especially designed to clean the toughest commercial jobs. To be used as a pretreatment to emulsify and loosen soils and stains. For hard water deposits, grout haze, efflorescence and soap scum use Snake Acid.

Dilution
1:1 - 1:100

Case: Includes 4 gallons



Super Nova Alkaline Cleaner

Super Nova is a concentrated heavy duty alkaline cleaner and restorer for deep cleaning of heavily soiled tile and grout. Safe for use on all polished surfaces. Super Nova is unmatched in it's ability to clean and restore stone and grout to it's original color. This non acid formula is safe to use on natural stone and will not etch the surface of the stone. An Alkaline based product is the first step in removing greases, oils and any sealers on stone and grout surfaces.

Dilution
1:8 - 1:10

Case: Includes 4 gallons

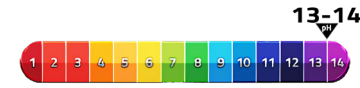

Snake Acid Acid Cleaner

Snake Acid is specifically designed for use on tile and grout which does not respond to other cleaning agents. It will remove lime, hard water deposits. Uric acid salts and various discolorations from toilet bowls, urinals, shower stalls, swimming pools, drinking fountains, wash basins and lavatories when used as directed. For use in industrial and institutional maintenance.

Dilution
1:4

Case: Includes 4 gallons



Grout Renewal Acid Cleaner

Grout Renewal is a safer alternative cleaner than harsh acids like phosphoric and muratic. It easily removes the embedded soil layer and renews the surface of the grout. This product is made with a proprietary organic acid that is twice as effective in dissolving calcium carbonate than phosphoric acid but is safer for the skin.

Dilution
1:1

Case: Includes 4 gallons

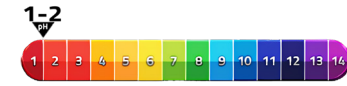

HARD SURFACE / CLEANING



Stone & Tile Neutral Cleaner

A daily neutral pH cleaner for all solid surfaces. Contains optical brighteners to enhance the look of the floor. Stone & Tile Neutral Cleaner's concentrated quick drying, streak free formula is perfect for use with an autoscrubber or mop and bucket applications.

USE ON: All stone surfaces, acrylic, glass, mirrors, chrome, and brass.

Dilution
1:20

Case: Includes 4 gallons



Flash Degreaser

Flash is a concentrated, heavy-duty butyl cleaner/degreaser.

For concrete cleaning:
Dilute 1 part Flash with 10 Parts water. Apply and scrub. Rinse after scrubbing.

Dilution

Floor Cleaning - 1:30
Concrete - 1:10
Stoves, Hoods, Ovens - RTU
Engines - 1:1
Pressure Washing - 1:100
Painted Surfaces - 1:40

Case: Includes 4 gallons



HARD SURFACE / STONE SEALING



Beauty Seal Concrete Sealer

Beauty Seal is a proprietary blend of acrylic polymers specifically designed to provide a higher level of durability than conventional water-based sealers. Beauty Seal is formulated for use on both interior and exterior concrete. Beauty Seal is resistant to water and many chemicals and oils. It is designed for easy application with no special acid etching or other preparation necessary. Simply deep clean the surface and apply Beauty Seal for a great looking, durable floor.

Ready to Use

Case: Includes 4 gallons



Beautiful Stone Stone Sealer

Beautiful Stone is a highly effective water based impregnating sealer formulated to help protect your stone surfaces from water and oil born stains. This sealer provides an invisible barrier resistant to stains, while allowing the surface to breathe. Beautiful Stone is a water based flouropolymer, impregnating sealer.

USE ON: All natural stone surfaces and cement based grout. For indoor and outdoor use. Always test a small area to check for desired outcome.

Coverage: 300-1500 ft/gallon

Cure Time:
May be opened to foot traffic in 2 hours.
Achieves a full cure in 24 hours.

Case: Includes 4 gallons



HARD SURFACE / WOOD FLOORS

Radiant Wood Floor CLEANER

Radiant Wood Floor Cleaner is a low-foaming nonionic surfactant with exceptional grease cutting performance. Radiant Wood Floor Cleaner will not streak, haze or leave a detergent film residue on cleaned surfaces. All purpose Radiant Wood Floor Cleaner is formulated to clean sealed wood floors while having a quick dry time to get the floor clean and ready for use in a small amount of time. Routine floor maintenance is quick and easy with Radiant Wood Floor Cleaner.



Concentrated Formula
2-4 ounces to 1 gallon

Case: Includes 4 gallons
Quart Case: 12 qt.



RTU

Radiant Wood Floor FINISHES

Two coats of Radiant Finish will give you a high level performance when applied over an existing solvent-based finish. Radiant is available Radiant Gloss and Radiant Satin Finish.



HARD SURFACE / VINYL / VCT

Forever Shine 22 Super Duty Floor Finish

Forever Shine 22 is a synthetic blend of high gloss polymers, leveling agent and drying solvents. Forever Shine 22, contains a new generation polymer that is chemically programmed to keep the finish shining brighter and wearing longer.



Diamond Coat Super Duty Floor Finish

Diamond Coat Floor Finish is a new dynamic blend of high gloss polymers, leveling agents and drying solvents. Diamond Coat Floor Finish contains a new generation rubberized polymer that is designed to keep the finish shining brighter and wearing longer. Diamond Coat Floor Finish resists scratching and gives the floor an exceptionally long wear life. Diamond Coat sets a completely new standard for floor finishes. It can be used on all resilient floors-vinyl asbestos, asphalt tile, vinyl sheet and tile, rubber, reinforced vinyl, and linoleum. Diamond Coat Floor Finish is specially formulated for low maintenance programs. Although it can be burnished on a regular basis, Diamond Coat will continue to shine without burnishing longer than traditional floor finishes.



Vanish Red Hot Stripper

Vanish is a special blend of water-soluble solvents and surfactant designed to emulsify as many as 10 coats of floor finish. It should be used on vinyl composition tile and other floors that will not be harmed by water-based solvents.

Dilution
1:4 - 1:10



EVERY LADY NEEDS A MIRROR



BEFORE

AFTER



GORILLATM
TRUCKBOX

HARD SURFACE LINE

HARD SURFACE / VINYL / VCT



Top Scrub

Top Scrub is specifically formulated for use in floor finish deep scrub and re-coat process. This unique concentrated no rinse cleaner, effectively removes the top layer of floor finish, leaving a film free surface ready for application of new layers of floor finish.

Dilution
4-8 oz. / Gal.



Reshine Cleaner & Restorer

Reshine is a unique floor care product that combines cleaning and restoring the floor surface in one step. Reshine works with existing floor finish to restore its buffable properties. Reshine is recommended for cleaning and restoring all types of resilient tile, vct, linoleum, terrazzo, and quarry tile.

Dilution
1-4 oz. / Gal.



Neutral Cleaner Low-Foaming Grease Cutter

Neutral Cleaner is a low-foaming nonionic surfactant with exceptional grease-cutting performance. Neutral Cleaner will not streak, haze or leave a detergent film residue on cleaned surfaces. This gentle cleaner is ideal for damp mopping floors. It picks up dirt and grime without harming floor finishes.

Dilution
2-4 oz. / Gal.





Spot Remover

Spot Remover will effectively treat and remove almost all common spills and stains. It will provide professional results against most food and beverage spills, blood, iodine, grease, tar, & smoke.



Spring Fresh Deodorizer

Spring Fresh Deodorizer absorbs odor molecules on contact and removes unpleasant odors instantly.



Urine Stain Remover

Urine Stain Remover removes that tough yellow stain on carpet and upholstery that is associated with pet stains. This product also eliminates any residual odors. It does not mask the odors it eliminates them.



Neutral Tile & Stone Cleaner

A daily neutral PH cleaner for all solid surfaces. Contains optical brighteners to enhance the look of the floor.



Wood Floor Cleaner

Wood Floor Cleaner is a low-foaming nonionic surfactant with exceptional grease-cutting performance. This product will not streak, haze or leave a detergent film residue on cleaned surfaces.

" I am so glad we made the decision to purchase the private labeled spotters for our company. Besides becoming our new customer favorite, and a great marketing tool, it has to be hands down the easiest sell ever! Thanks so much for making such a great product available! "

- Brenton McEntire G.M. Dynamic Carpet Care LLC

What does private labeling do for you?

- It makes your customer remember you.
- You'll be marketing your chemical, not some chemical manufacturer. Everything on the label will point back to you and your company.
- A QR code helps drive customers to your website.
- You can make a 50% profit when selling to your clients or customers at trade shows.
- It can be used as a give away to sell other services.



YOUR COMPANY COLOR SCHEME

DESCRIPTION
Spot Remover was developed with space age technology by cross linking incompatible chemicals and bonding these with unique wetting and emulsifying agents. Spot Remover will effectively treat and remove almost all common spills and stains. It will provide professional results against most food and beverage spills, blood, iodine, grease, tar, pet stains, smoke, also makes a great laundry booster.

SPOT REMOVER is environmentally safe, non-toxic, non-hazardous, non-corrosive, non-caustic, non-flammable, biodegradable, water soluble. Spot Remover has no high solvents, acids, alkaline, caustics, phosphates or strong fumes.

DIRECTIONS FOR USE
Always pretest for colorfastness and fiber distortion in an inconspicuous area. Apply solution liberally to spot. Agitate into spot and allow solution to dwell 3 to 5 minutes. At a minimum, blot area with clean white absorbent towel. For best results rinse and extract with water.

STORAGE AND DISPOSAL
Store tightly capped in original container with label intact. DO NOT contaminate water, food or feed by storage or disposal. Dispose of empty container after triple rinsing. Do not reuse empty container.

Scan this with a qr code scanner from your phone to visit our web site.

**Superior Cleaning Power & Effectiveness*

SPOT REMOVER

CARPET & UPHOLSTERY STAIN REMOVER

YB YOUR BRAND

WWW.YOURBRANDLABEL.COM 918.401.0520

FOR INSTITUTIONAL AND COMMERCIAL USE

BEFORE USING THIS PRODUCT PLEASE READ ALL PRECAUTIONARY STATEMENTS.

CAUTION
KEEP OUT OF REACH OF CHILDREN. Causes eye damage. Do not get in eyes. May cause skin damage. Do not get on skin. Harmful if swallowed. Do not swallow.

FIRST AID
Eye contact: Remove contact lenses. Immediately flood eyes with water for at least 15 minutes holding eyelids apart. Seek medical attention.

Skin Contact: Remove contaminated clothing. Rinse skin with running water for at least 15 minutes and until all traces of product are gone. If skin irritation persists, seek medical attention.

Ingestion: If swallowed, drink at least 3-4 glasses of water or milk. Seek medical attention.

Inhalation: If inhaled, remove victim to fresh air. If irritation persists, contact a physician.

IN CASE OF ACCIDENTAL INGESTION CONTACT PHYSICIAN OR LOCAL POISON CONTROL CENTER.

See Material Safety Data Sheets (MSDS) and additional safety and regulatory information.

QR CODE

YOUR LOGO & CONTACT INFO



GORILLA TRUCKBOX™

BETTER DILUTION. BETTER PRICES. BETTER PRODUCTS.

THE GORILLA CRUSHES THE COMPETITION

WWW.GORILLATRUCKBOX.COM/CHEMICALS



GORILLA TRUCK BOX™
TOLL FREE: (888) 313-8173
E: tulsa@gorillatruckbox.com
www.gorillatruckbox.com

WARRANTY AND RETURNS: Any products sold with a factory warranty may be returned if found defective within the terms of the warranty. Please call a Gorilla Truck Box representative to get details on how to return damaged items. | **DAMAGE IN SHIPMENT:** All claims for materials damaged during shipping must be reported to the delivering carrier. | **PRODUCTS AND PRICING:** There are many chemicals and accessories, and parts that we sell that are not listed in this catalog. We will continue to revise this catalog periodically to get these products added. If there is a product you are needing that you do not see listed, feel free to give us a call. Prices or payments listed in this catalog are not necessarily up-to-date. Please call us to get accurate and current pricing or to find out about financing a new van, a Gorilla Truck Box, and cleaning and restoration equipment.